

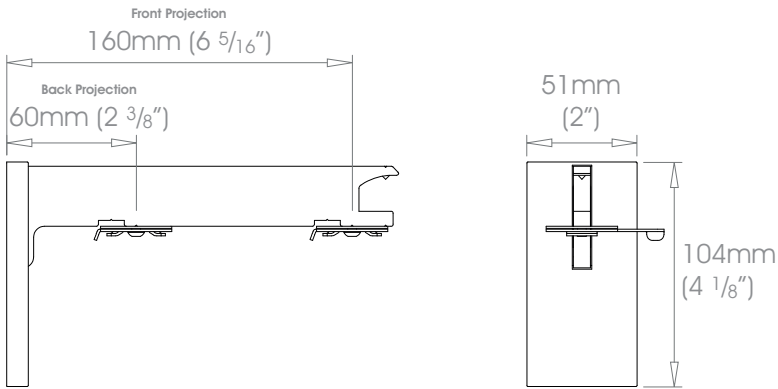

⚠ Brackets will be supplied with the relevant track fixing, which may differ to those shown in the diagrams

<b>FINISHES</b> Coat Options Matte ⊕ Satin ⊕ Gloss ⊕	<b>Stainless</b> Shades ⊕⊕⊕	Brushed Stainless Cloud • Alabaster • Bone • Barley • Dusk • Ceramic • Cream • Mineral • Dove • Parchment • Oatmeal • Millstone • Stone • Clay • Grey Moss Slate • Cocoa • Moss • Damson • Smoke • Frame Grey • Lead • Earth • Burnt Ash • Flint • Charcoal • Raven
	<b>Metallics</b> ⊕⊕	Platinum • Champagne • Gold • Cognac • Antique Brass • Gunmetal • Pewter • Bronzed
	<b>Anodic Metals</b>	Twilight • Glow • Sky • Sunrise • Storm • Glimmer • Sunset • Night Sky • Midnight
	<b>Specialist</b>	Can be specified at twice the cost of the standard finish - Brushed Brass Tint • Brushed Bronze Tint • Brushed Carbon Tint   Polished Nickel
	<b>Custom</b>	Can be specified at twice the cost of the standard finish plus a custom fee - Old Brass • Light Bronze • Bronze Art See page 19 for details

**Front 50mm (2") - Back Uncovered**



**Front 50mm (2") - Back 50mm (2")**

